

AUTOMIX 100

Electronic Temperature Control

MOUNTING AND OPERATING INSTRUCTIONS

Automix 100 is an electronic temperature control for hydronic radiator and radiant floor heating applications.

Automix 100 is ready for mounting and can easily be integrated in new and existing heating systems. Automix 100 works continuously and proportionally. Through impulses from the sensors the controller directs the motor to keep the valve plug in the position that corresponds to the actual heat requirement of the house.

FUNCTIONS

1. Quartz or digital programmer with night set-back, spring reserve, weekly program facility.
2. Adjustments for minimum and maximum supply water temperatures
3. Freeze protection
4. Adjustable booster function.
5. Automatic pump operation

AUTOMIX 100 INCLUDES

1. Electronic controller, quartz or digital programmer with spring reserve
2. Valve motor 24 VAC 50/60 Hz with 1,5 m wire
3. Supply water sensor T1 with 3 m wire
4. Outdoor sensor T2 with 15 m wire
5. Electronic room sensor T3 Order No. 7005 (Optional)

CONTROLLER

- | | |
|------------------------------|---|
| A. Quartz programmer | I. Time marking arrow |
| B. Pegs | J. Program selector |
| C. Graph setting | K. Yellow LED – Booster function on |
| D. Parallel displacement | L. Yellow LED – Temperature set-back on |
| E. Temperature set-back | M. Green LED – Power on |
| F. Booster function | N. Red LED – Mixing valve opens |
| G. Min. supply water limiter | O. Red LED – Mixing valve closes |
| H. Max. supply water limiter | |

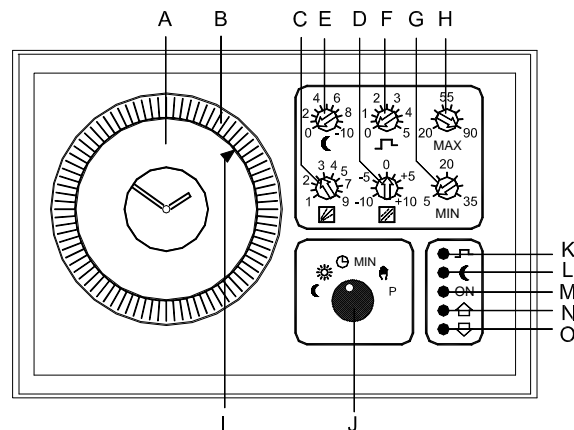

MOUNTING

Controller

The socket is mounted on a wall, panel or rail and the controller is placed on the socket.

Supply water sensor T1

Sensor T1 is fastened in a non-insulated part of the supply pipe 1 m after the mixing valve. For optimal temperature measuring the pipe has to be insulated afterwards.

Outdoor sensor T2

Sensor T2 is mounted on the north or north-western outside wall at least 3 meters (9 feet) above ground. The outdoor sensor must never be mounted above a window or near an air valve as this would influence the sensor.

Room sensor Automix T3 (optional)

Sensor T3 is mounted at a place with an average temperature of the house. The room sensor should not be placed where it can be affected by direct sunshine, heat radiation or draught. Radiator valves should not be installed in the same room as sensor T3.

AUTOMIX 52 VALVE MOTOR

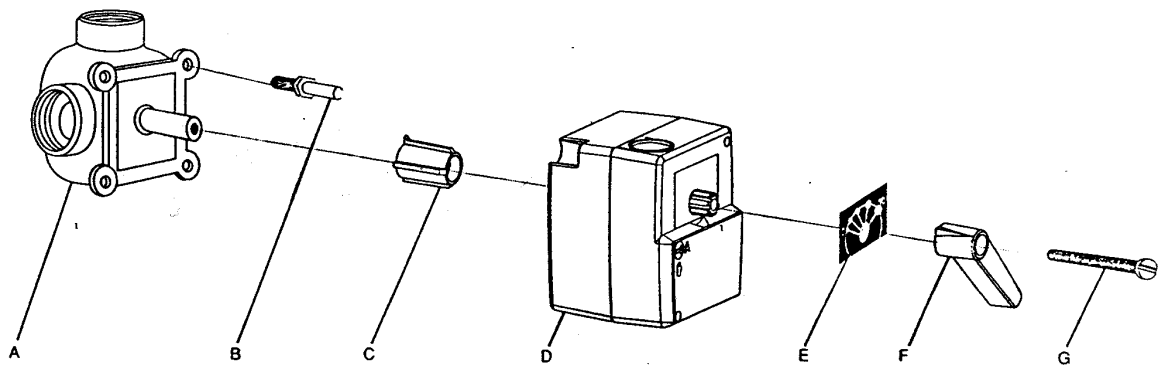

1. Turn the spindle of the valve **A** counter clockwise to the end position (open or closed). Remove the knob/handle without changing the position of the spindle. Fasten the socket **I** with screws **J** or fasten the socket **K** to the wall.
2. Screw the anti-rotation stop **B** in a convenient hole on the valve (if necessary remove an existing screw).
3. Slide the linkage **C** over the valve spindle. Place the motor **D** onto the linkage **C** until the antirotation stop **B** engages in the slot of the motor.
4. The motor is supplied in the anti-clockwise position. Turn the scale **E** according to the open/closed direction of the valve.
5. Place the handle **F** onto the motor ensuring that the arrow points to the left end position of the scale. Tighten the handle unit by means of screw **G**.
6. Using a screwdriver (No.3) turn the disengaging button **H** from "A" to "HAND" position and rotate the valve by means of handle **F** from one end position to the other. **It is important that the motor can be moved from one end stop to the other (90°)**
7. Connect the motor wire to the MOTOR-connection on the control unit.
8. Turn the disengaging button **H** back to "A" which is the AUTOMATIC-position.

WIRING

Take the cover off. Remove controller from the mounting plate by loosening the two screws on the corners and lift out.

WIRES

Main supply 3 x 1,5 mm²
 Sensors 2 x 0,5 mm²
 Motor 3 x 0,5 mm²
 The wires can be lengthened

- T1 = Supply water sensor
- T2 = Outdoor sensor
- T3 = Room sensor
- M = Valve motor
- P = Pump

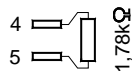
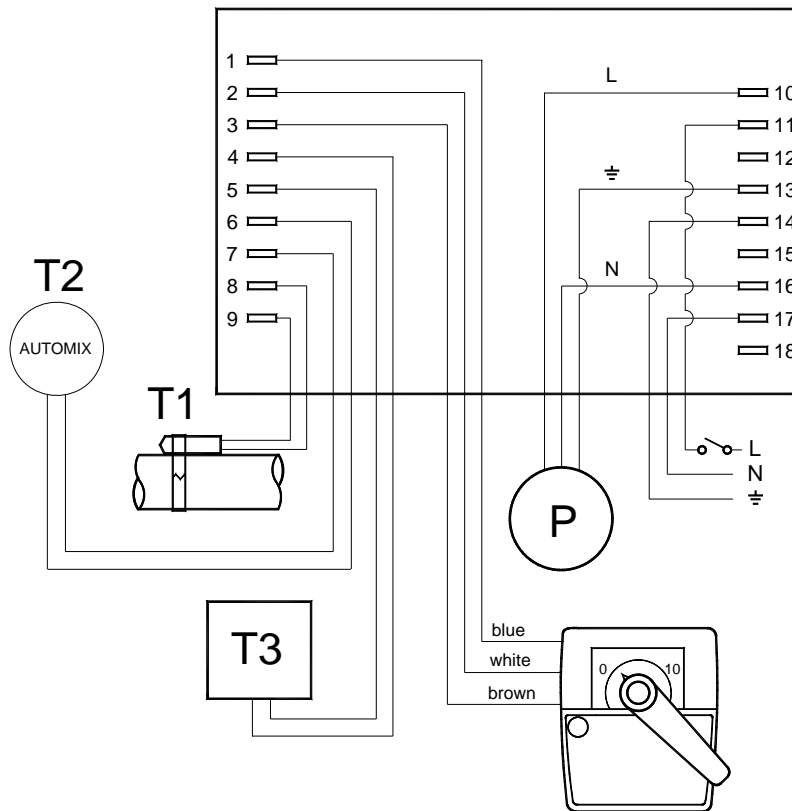

With this wiring the motor opens to the right.
 To make the motor open to the left
 change wires 2 and 3.

ROOM SENSOR AUTOMIX T3

Before the room sensor Automix T3 is connected the 1,78 kOhm resistor in the connection block 4 and 5 must be removed.

GRAPH SETTING

The regulating graph for a certain house is dependent on dimensions, location, insulation etc. Therefore it is not possible to decide on a graph in advance. It will have to be tried out.

The graph is set with knobs **C** and **D**. The knobs work steplessly. Knob **D** grading $\pm 10\text{ }^{\circ}\text{C}$ means that the supply water temperature can be raised or lowered by $10\text{ }^{\circ}\text{C}$ from setting 0.

Starting values: Regulating graph for radiator heating, set knob **C** on 6.
Regulating graph for floor heating, set knob **C** on 3.

In the room temperature rises with falling outdoor temperature, lower knob **C**. If the room temperature falls with falling outdoor temperature, raise knob **C**. Make only very small changes with knob **C**. When the house has an even temperature despite fluctuating outdoor temperatures, the correct regulating graph has been obtained.

The room temperature can be raised or lowered with knob **D**.

N.B! Heat affects slowly. When the temperature setting has been changed it takes some hours before the room temperature corresponds to the new setting due to dimensions of the heating system and the insulation of the house. A floor heating system responds slower to the new setting than a radiator system.

Supply water temperature

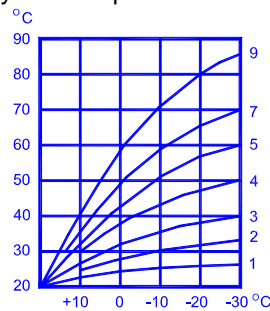

Outdoor temperature

PROGRAMMER

ART. NO. 1228 AUTOMIX 100 with OQUARTZ-PROGRAMMER

Hydronic heating systems and especially floor heating systems respond slowly to program changes. After a change in setting it takes one to several hours before the new selected temperature is actually reached. Consequently, temperature set-backs and set-ups must be set 1-2 hours earlier than the desired time.

1. **Primary setting:** Turn switching dial in the direction of the arrow until the current weekday is opposite the marking arrow **I**.

Secondary setting: Continue turning the minute hand in the direction of the arrow until the current time is opposite the marking **I**.

2. The control comes with the factory preset switching times. Night set-back starts at 22.00 hours and day temperature at 6.00 h. The control is easily re-programmed. The temperature set back is changed by pressing the desired amount of pegs towards the edge of the programmer. One peg equals two hours. Return to day temperature occurs the next unpressed peg.
3. Shortest make-time is 2 h.
4. The quartz programmer has a spring reserve of 150 h.

ART.NO 1229 AUTOMIX 100 WITH DIGITAL PROGRAMMER

To program the digital programmer, see the enclosed instruction.

TEMPERATURE SET-BACK

Temperature set-backs are adjusted with knob **E**. The knob **E** grading means supply water temperature. When the programmer gets to a peg that has been pressed towards the edge of the programmer the temperature set-back starts.

A 5 °C set-back of supply water temperature equals about 2 °C in room temperature. At the first unpressed peg the program returns to day temperature.

When the room sensor Automix T3 is connected the knob **E** grading means room temperature.

BOOSTER-FUNCTION

The booster function provides a higher supply water temperature after a temperature set-back. When the programmer gets to the first un-pressed peg the normal temperature starts. To reach the normal room temperature more rapidly a higher supply water temperature is possible during 70 min.

A higher supply water temperature is set with knob **F**. The grading is °C supply water temperature.

MIN./MAX. SUPPLY WATER TEMPERATURE

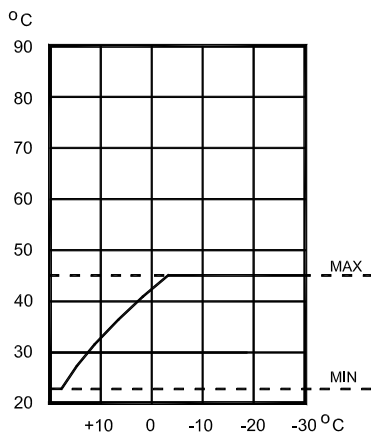

Setting min./max. Temperature of supply water temperature is used in floor heating systems.





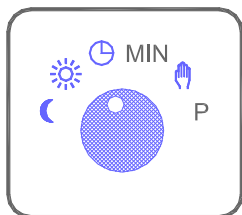

Maximum supply water temperature is set with knob **H** and minimum with knob **G**.

In the example the max. supply water temperature is set to +45°C and the min. to + 22°C

The supply water temperature stays between max. and min. supply water temperature.

PROGRAM SELECTOR



-  Set-back temperature
-  Day temperature
-  Automatic program
-  MIN /Summer setting. Freeze protection
-  Manual setting
-  Pump runs always. Day temperature

When using MIN/Summer setting with freeze protection the clock runs. The freeze protection never allows the supply water temperature to sink below adjusted level.

At MIN/summer setting the pump normally does not run. The valve is closed. An interval control starts the pump and the valve for a short time every other day. This prevents the pump and the valve from getting stuck.

At manual setting the motor valve does not work. The pump runs. The valve can be adjusted manually by Turning the knob “**A**” on the motor to “**HAND**” position and turning the motor knob in desired direction. Emergency operation!

KNOB ON THE BACK

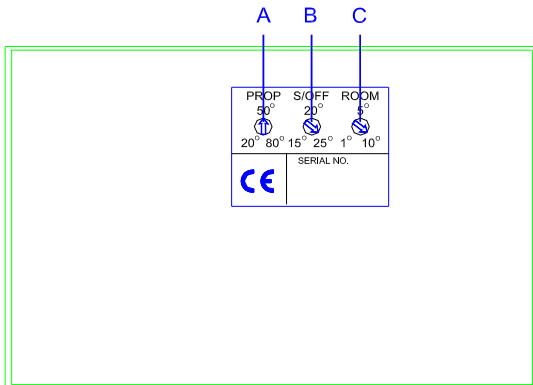

- A. Proportional adjustment
- B. Warm weather pump shut down
- C. Room sensor compensation

PROPORTIONAL ADJUSTMENT

The regulating graph can be widened with knob A. This function is used if the supply water temperature fluctuates owing to considerable differences between supply and return water temperatures.

WARM WEATHER PUMP SHUT DOWN

The outdoor temperature at which the pump will stop is set with knob B. When the outdoor temperature sinks below this value the pump will automatically start.

ROOM SENSOR COMPENSATION

If no room sensor is connected knob C should be set at **1 °C**. When connecting a room sensor the resistor in the connection block 4 and 5 must be removed. After having connected the room sensor knob C must be set at **10 °C**. The knob E. grading now means room temperature.

TROUBLE SHOOTING

N.B! Heat affects slowly. When the temperature setting has been changed it takes some hours before the room temperature corresponds to the new setting due to dimensions of the heating system and the insulation of the house. A floor heating system responds slower to a new setting than a radiator system.

If the heating system should not work satisfactorily – check that:

1. The boiler or storage tank temperature is correct.
2. The power is on
3. The circulating pump is working
4. The power is on and the fuses are unbroken.
5. The radiator and gate valves are open
6. The wiring is correct
7. The program selector is in a correct position
8. The programmer is working and the pegs are correctly placed.
9. There is no air in the heating system
10. The mixing valve turns easily
11. The knobs are in correct position
12. At least one radiator does not have a thermostatic radiator valve to guarantee circulation.
13. The resistance/temperature relations are corrected according to the curves below.

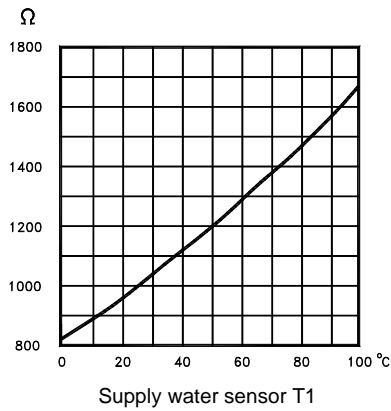
SENSOR RESISTANCE

°C	Ω
0	820
10	889
20	962
30	1039
40	1118
50	1202
60	1288
70	1379
80	1472
90	1569
100	1670

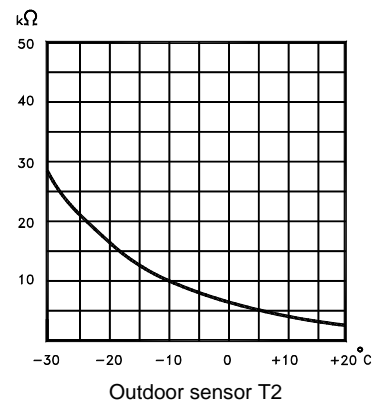

°C	k Ω
20	2,67
15	3,28
10	4,06
5	5,04
0	6,31
-5	7,93
-10	10,05
-15	12,84
-20	16,54
-25	21,40
-30	27,93

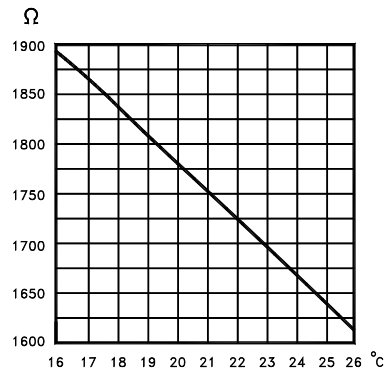

Room sensor AUTOMIX AM3/T3

TECHNICAL DATA

Type of control	PI-control with microprocessor
Voltage	230 VAC 50/60 Hz
Power consumption	5 VA
Heating curve	1 - 9, stepless
Parallel displacement	+/- 10°C
Min. supply water limiter	+ 5°C - + 35 °C, stepless
Max. supply water limiter	+20 °C - +90°C, stepless
Freeze protection	+5°C - +35°C, stepless
Manual operation	Yes, in case of power failure
Booster function	45 min, 0 - 5°C, stepless
Protection class	IP 40
Optional	Electronic room thermostat Order No. 7005
Warm weather pump shut down	15°C - 25°C, stepless
Torque	5 Nm with motor 6052, 10 Nm with motor 6053
Angle of rotation	90 °
Dimensions, controller	72 x 90 x 144 mm
Mounting	Wall, panel or rail DIN EN 50 022
Weight	1,5 kg